

MANUAL  
**RC6**  
**NOVO**





# Contents

<b>Product Information</b> .....	<b>6</b>
<b>Settings / adjustments</b> .....	<b>7</b>
<i>Initial operation</i> .....	7
<i>Recumbent settings</i> .....	7
<b>Overview</b> .....	<b>8</b>
<b>Operating Instruction</b> .....	<b>9</b>
<i>How the bike works</i> .....	9
<i>Power on crank or flywheel</i> .....	9
<i>Pulse measurement</i> .....	9
<i>If you use chest belt</i> .....	9
<b>Validation</b> .....	<b>10</b>
<i>Checking the pulse function</i> .....	10
<i>Scale adjustment</i> .....	10
<i>Validation of force</i> .....	11
<b>Monark novo control unit</b> .....	<b>12</b>
<i>Connection to external control unit</i> .....	12
<i>Communication protocol (command type)</i> .....	12
<i>Command type settings</i> .....	13
<i>Set commando type for the RS232 port</i> .....	13
<i>Monark test software</i> .....	13
<i>Other external PC software</i> .....	13
<i>Terminal mode PC</i> .....	13
<b>Monark novo display unit</b> .....	<b>14</b>
<i>Start training</i> .....	14
<i>Stop / pause training</i> .....	15
<i>Workload control</i> .....	16
<i>Menu</i> .....	17
<i>Set a target</i> .....	17
<i>Exercise target achieved</i> .....	19
<i>Pulse settings</i> .....	20
<i>Bluetooth SMART</i> .....	20
<i>ANT+</i> .....	20
<i>If you use chest belt</i> .....	20
<i>Settings general</i> .....	21
<i>Connect Bluetooth SMART heart rate monitor</i> .....	22
<b>Calibration</b> .....	<b>24</b>
<b>Testing with RC6 novo</b> .....	<b>26</b>
<b>Troubleshooting guide</b> .....	<b>28</b>
<b>Service and Maintenance</b> .....	<b>30</b>
<b>Spare parts list</b> .....	<b>34</b>

## Important

Read the manual carefully before using the cycle  
and save it for future use.

## Monark Exercise AB

Monark has 100 years' experience of bicycle production. The Monark tradition has yielded know-how, experience, and a real feel for the product and quality. Since the early 1900s, Monark bikes have been living proof of precision, reliability, strength and service. Those are the reasons why we now are the world leader in ergometer bikes and the market leader in Scandinavia in transport bikes.

We manufacture, develop and market ergometers and exercise bikes, transport bikes and special bikes. Our largest customer groups are within health care, sports medicine, public authorities, industry and postal services.

For more information: <http://www.monarkexercise.se>



## *Thank you for choosing a test cycle from Monark!*

Ideal position is important for performance to reach its maximum. The many adjusting options, along with an upgraded braking system, make Monark's renowned bike even better.

RC6 novo gives the conditions; the rest is up to the rider.

In today's society we are used to customizing our machines and tools for our own needs. The same applies to RC6 novo. Through intelligent solutions parts can be customized according to user requirements. RC6 novo is a great bike as it is, with additional equipment, it can be even better.

Force is a strong word which has many associations. For us, force is interesting when it can be measured and calibrated. For a brake-force to be correct, regardless of the system, it must be calibrated and controlled. On RC6 novo brake system and calibration have been updated so that it is safer and more accurate. It is also quicker to adjust and has more options in that it is speed-independent, but can be switched into constant braking force as an alternative.

Monark has always been known for the bikes measurement accuracy, now it's even better.



# Product Information

## NOTE!

Use of the product may involve considerable physical stress. It is therefore recommended that people who are not accustomed to cardiovascular exercise or who do not feel completely healthy, should consult a physician for advice.

## Technical details

Length	1900 mm
Width	680 mm
Height (max at display)	1065 mm
Height (max at seat)	1000 mm
Weight	107 kg (calculated)
Weight flywheel	20 kg
Max user weight	250 kg
Painting	Industrial powder coating
Rust protection	Basic powder coating on exposed areas
Crank	Steel, 52T, 170 mm standard, 172.5 mm optional
Pedals	9/16" with foot straps
Seat	Rotatable recumbent seat
Handlebar	Not adjustable recumbent handlebar
Distance seat - handlebar	80-470 mm

## Power output

Continuous (50-100 rpm)	4-700 W
Peak (at RPM)	1400 W (200 RPM)
Smallest increment	1 W

## Features (PC software)

- $VO_2$  submax test
- Training/test protocols (custom)
- $VO_2$  max test
- $VO_2$  controlled

## Features (external equipment)

- ECG work test
- Equipment for testing of oxygen uptake
- Other Ergoline compatible device

External control is via RS232 and USB-B. Data outputs can be used simultaneously, in parallel with each other

## Technical data power adaptor

Input voltage: 100-240 V AC; 50-60 Hz; 1.4-0.7 A

Output voltage: 12 V DC; 5.0 A; 60 W max.

Polarity: + in the middle, see *Fig: Polarity*.

Art. No: 9311-9311-1



*Fig: Polarity*

## NOTE!

If you replace the original power adaptor, the replacement must be CE marked or equivalent. It must also have the correct polarity and voltage.

## Pulse registration

The bike has a module that registers the heart rate data from heart rate belts, or similar, with ANT+ or Bluetooth SMART profile. We recommend, for example, "Polar H7", which we have tested and that works well.

## PC software

Software to control the bike, and to do different tests, is available to download from our website: [www.monarkexercise.se](http://www.monarkexercise.se).

## Serial number

The serial number is placed according to *Fig: Overview* at page 8.

## Included

- Calibration weight 4 kg
- Chest belt Polar H7, Bluetooth SMART
- Tool kit
- Power adaptor
- 0-modem cable (RS232)
- USB A-B cable

**The bike can be used at maximum load without any time limit.**

# Settings / adjustments

## NOTE!

Before using the bike - remember to remove the pendulum transport locking.

## Initial operation

RC6 novo is mechanically calibrated at the factory. The user can always verify this by performing the mechanical calibration of the pendulum. See section "Calibration pendulum".

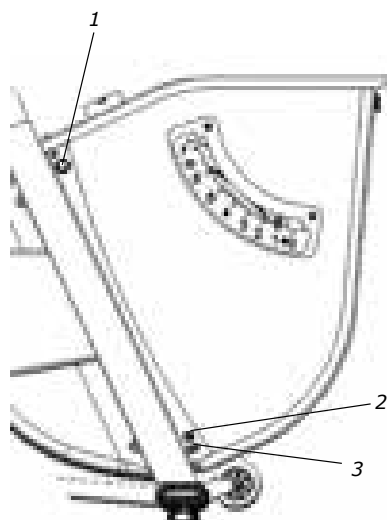
Apply power to the bike by first connecting the cable from the power adaptor to the bike at the power connector (3) at the right side of the bike, see *Fig: Front cover right*. Then plug the power adaptor into the wall outlet. Turn on the power switch (1) and a green LED lights up.

The cable from the power adaptor can be locked with the clamp (3) which is placed below the power connection.

Perform the electrical calibration as specified in section "Calibration Electronics". Test by pedalling the bike. If the bike is working properly, it is ready for use.

*Fig: Front cover right*

- 1) Power switch with LED
- 2) Power input
- 3) Locking for cable (power adaptor)



## Recumbent settings

When you ride on the recumbent you should adjust the distance to the pedals so that you get a comfortable seating position. You can adjust the seat longitudinally by lifting the lever on the right side and push the seat forward / backward. Once you find the correct position, release the lever and make sure it locks (a click is heard).

To change the seat-back tilt, pull out the sprint to the right and help with the other hand to change the tilt. Once you find the correct position, release the lever and make sure it locks (a click is heard). See *Fig: Adjustments*.

For easy entry and exit, the seat can rotate 90° and be locked in this position. This is done by lifting the lever (2), and keep it lifted, while you rotate the seat. The seat can be locked in four different positions - straight ahead, straight both sides and straight back. When the seat is in position, release the lever and feel that it locks.



*Fig: Adjustments*

*Length adjustment of seat*

- 1) Lift the lever. Move the seat forward / backward.

*Rotating the seat*

- 2) Lift the lever. Rotate the seat.

*Adjustment of seat-back tilt*

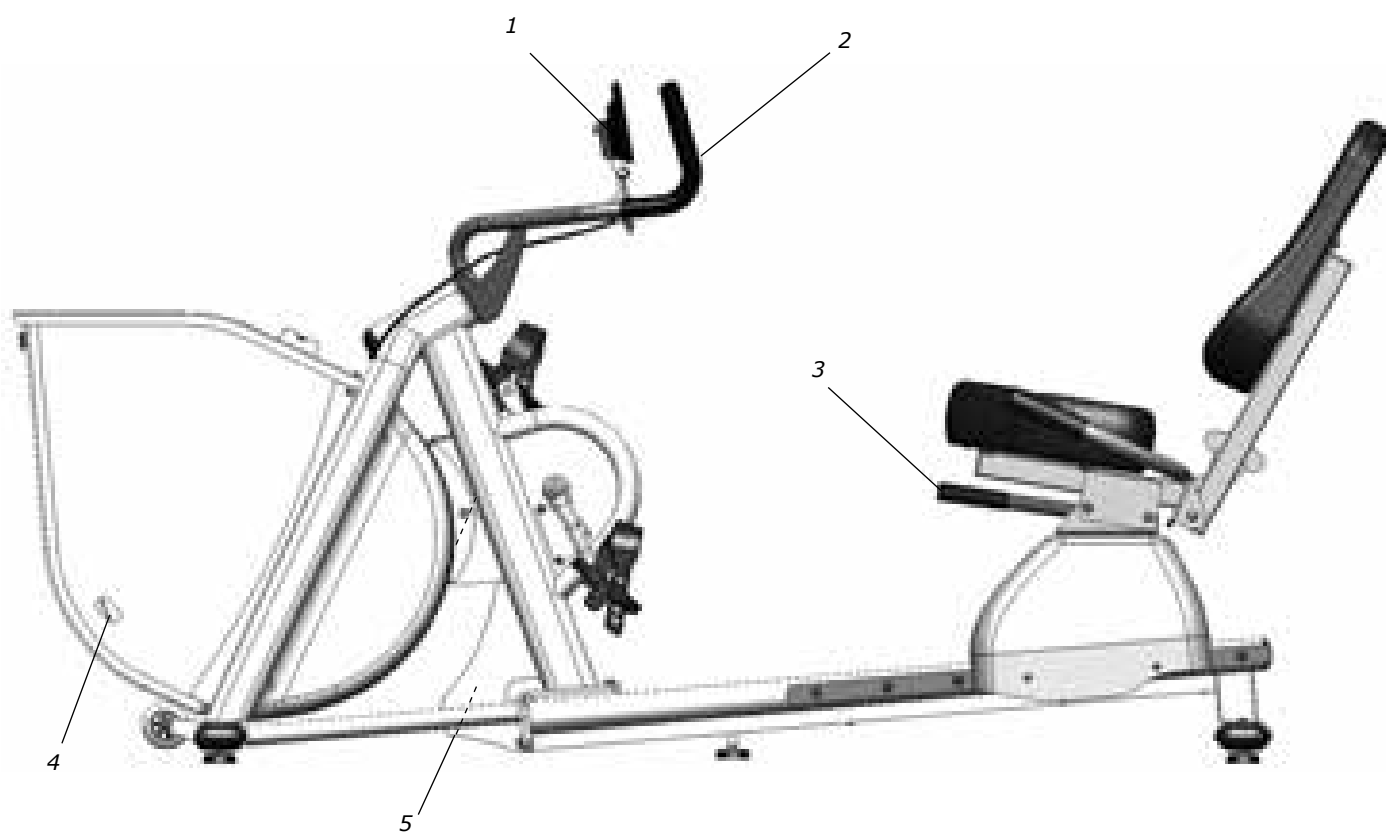
- 3) Pull out the sprint

- 4) Adjust the seat-back tilt

# Overview

*Fig: Overview*

- 1) Monark novo display unit
- 2) Recumbent handlebar
- 3) Lever for turning the seat
- 4) Opening in the side cover for the connection of external equipment
- 5) Serial number (on reverse side)





# Operating Instruction

Here are instructions for connection and options for connection to external devices. If advanced technical documentation / data protocol for system builders or similar are required, please contact Monark Exercise AB.

## How the bike works

RC6 novo is based on a stable frame, large well balanced flywheel, brake belt and a pendulum that measures the braking force. The pedals operate around the flywheel via a chain, while a stretch mechanism tightens the brake belt to regulate the braking force to affect the flywheel. This braking force can be read directly by the pendulum on the scale on the right side of the bike.

All changes in the friction between the brake belt and the flywheel are compensated automatically by Monark's unique construction.

New on RC6 novo is that you can control the bike from the display but the bike can, as earlier models, even be controlled externally from PC or other equipment. The display functions are described in section "Monark novo display unit". The computer system consists of Monark novo control unit (built in the bike) and Monark novo display unit, PC or other external device. Monark novo control unit registers pedal speed and braking force, and also registers the test person's heart rate if a chest belt or similar is used. Monark novo control unit activates an actuator that adjusts the brake belt tension, which regulates the workload. This workload is varied automatically in relation to changes in pedal speed, so that a constant power is maintained. The bike is standard RPM independent but can be set to also be RPM dependent (constant force).

On RC6 novo both RS232- and USB-B-ports are located on Monark novo control unit behind the left side front cover. These can be freely used to connect external devices such as PC, ECG, spirometry, etc. for which the external device can control the workload and get real-time data such as power, rpm, pulse and more from the bike.

For information about how respective control units work, see section "Connection to external control unit".

## Power on crank or flywheel

Monark bikes measure the effect of the flywheel, so it will be a friction of 6-8% if you measure the impact of the pedals (if the effect is measured on the crankshaft, the difference is 4-5 %). The losses will be primarily due to friction in the chain, pedals and bearings in the wheels and crank.

RC6 novo is designed for fitness tests and are set to measure the power at the flywheel, which is the traditional way in submaximal exercise. The bike can be set to work with effect in the pedals / crankshaft (the cycle constant).

## Pulse measurement

The person's heart rate ("pulse") can be measured by a chest belt, or similar heart rate monitor, that register the pulse signal from your heart and sends it to the bike with ANT+ or Bluetooth SMART technology. More information is available in section "Monark novo display unit".

The heart rate can be displayed in Monark novo display unit, in Monark test software or in other external device.

## If you use chest belt

Heart rate monitoring requires that the chest belt is correctly placed. When it is correctly fitted the logo on the belt will be central and readable, outward and upright, by another person. Before putting on the belt, clean the skin where the belt is to be placed. The chest belt should be secured at a comfortable tension around the mid section, just below the breast muscle, see *Fig: Placement chest belt*. Moisten the electrodes before use, see *Fig: Moistening the electrodes*.

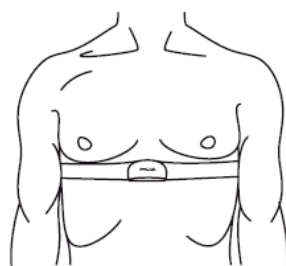


Fig: Placement chest belt

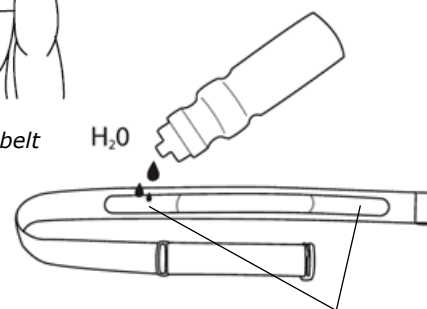


Fig: Moistening the electrodes

The images above are used with permission of Polar Sweden.

## Validation

The following controls ensures that the bike works for daily use.

- Checking the pulse function
- Check the adjustment / zero of the scale
- Check the braking force
- Test by pedalling and check that a reasonable RPM is obtained - verify by a clock. Feel if the pedals move smoothly. Listen for unusual sounds. Adjust if necessary.
- Adjust the handlebar and saddle and make sure they are securely attached and that the adjustment is working properly.
- Make sure the support legs are in position by rocking the bike. Tighten if necessary.

If something unusual is found during the daily inspection that you cannot resolve, please call customer service.

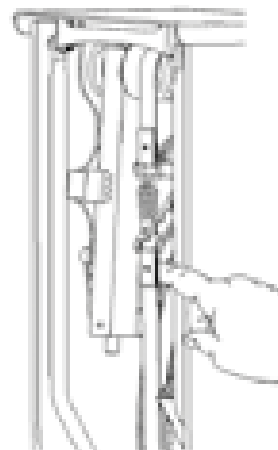
### Checking the pulse function

On RC6 novo the heart rate is displayed in Monark novo display unit. The heart rate can also be displayed in other external device.

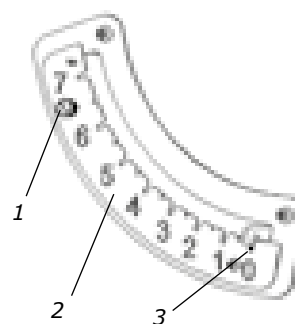
While the patient rests, with the chest belt on, compare the displayed heart rate (Monark novo display unit, PC or other) with the manually taken pulse. If it does not correspond, check the chest belt contact area and if necessary moisten the electrode surfaces with water.

### Scale adjustment

First check that the brake belt is loose, see *Fig: Checking loose brake belt*. If not, move the pendulum to 4 kp and hold it there a while to loosen it. Then check that the pointer on the pendulum is aligned with the 0-index (3) on the scale (2). If not, you need to adjust the scale. Loosen the pole screw (1) (do not unscrew it completely), and adjust the scale so that the 0-indices and indicators are consistent. Tighten the pole screw again as the scale is locked into position. See *Fig: Scale adjustment*.



*Fig: Checking loose brake belt*



*Fig: Scale adjustment*

- 1) Screw
- 2) Scale
- 3) 0-index

## Validation of force

### Monark novo display unit

Start up the the bike and ensure that Monark novo display unit starts up. Select “Settings” and then “Maintenance”. Then read the "kpscale value" to see the pendulum angle.

1. With the pendulum pointer at 0, the display should show approx. "0.000".
2. Move the pendulum pointer to 4 kp and the display should show approx. "4.000".

If the braking force is not displayed correctly, an calibration of the pendulum has to be done. See section "Calibration".

#### NOTE!

After this verification, the brake belt will be loose. This means that it will take some seconds before the regulating device has tensed the brake belt to normal again after you have started pedalling. If it then heavy to pedal, add force on the pedals and the bike will drop on the work load until it is possible to pedal around.

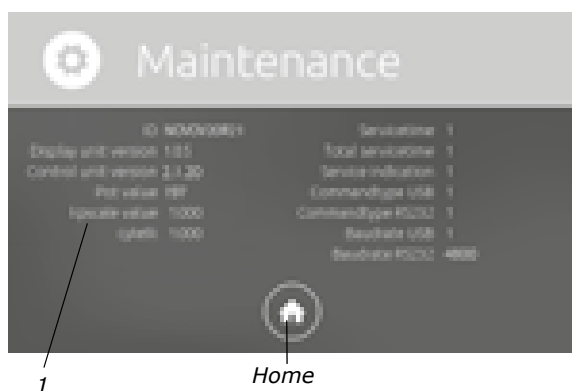


Fig: Maintenance  
1) kpscale value

## Validation of force

### Monark Test Software (MTS)

Start Monark Test Software (it is available for free download from our web site: [www.monarkexercise.se](http://www.monarkexercise.se)) and select a test programme from the menu "Test". In the dialogue box that opens is a box showing the braking force in Newton, see *Fig: Force and HR display*. You do not have to press "Start" (1) to get the heart rate showed (2), but you must press "Start" to show the force (3).

1. With the pendulum pointer at 0, the display should show "00N"
2. Move the pendulum pointer to 4 kp and the display should show "39N"

If the braking force is not displayed correctly, a calibration of the pendulum has to be done. See section "Calibration".

#### NOTE!

After this verification, the brake belt will be loose. This means that it will take some seconds before the regulating device has tensed the brake belt to normal again after you have started pedalling. If it then heavy to pedal, add force on the pedals and the bike will drop on the work load until it is possible to pedal around.



Fig: Force and HR display  
1) Start  
2) Heart rate display  
3) Force in PC software (manual test)

# Monark novo control unit

## Connection to external control unit

No tests can be performed at Monark novo display unit, then you must connect your bike to a PC, via the Monark novo control unit, and use a special test software. A suitable one is available to download from our website: [www.monarkexercise.se](http://www.monarkexercise.se).

The bike do not need to be switched off when connecting external components, but it is recommended, to prevent transmission of incorrect data. This is to avoid the transmission of incorrect data.

Be careful when connecting different types of external devices to prevent flash-over and subsequent injury. The user must be certain that the instrument connector and the cable are designed for the intended purpose. Serious injury to the user and / or equipment may result if inappropriate connections are attempted.

### Connect external device via RS232 and USB

Make sure the power adaptor is connected to the bike. Turn off the power switch on the bike.

Both RS232 port and USB-B port are located on Monark novo control unit behind the left side front cover. Open the front cover to access Monark novo control unit. You can pass the cable you want to connect through the cable inlet in the left side cover. Remember to lock the cable in the strain relief.

Connect the RS232 first to Monark novo control unit, located behind the left side cover, and then to the external device. Set the bike power switch to "on" and then start the external device.

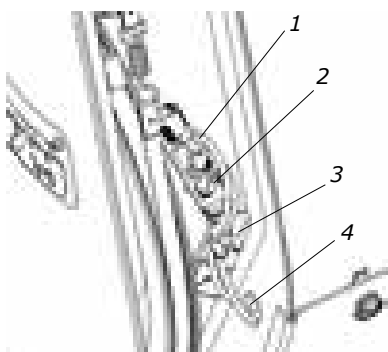
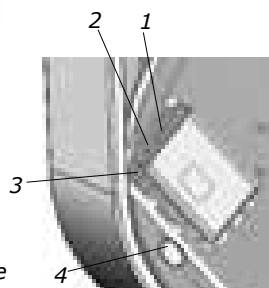


Fig: Connections  
1) RS232 port  
2) USB-Bport  
3) Strain relief  
4) Cable inlet



The side cover is transparent in the figure

## Communication protocol (command type)

The bike's two free ports can be set in various command types to suit different standards and external devices. The four available command types are:

### 0: Standard command set or "PC-mode"

Command type "0" is default for both of the free ports. As default the baud is 4800, but can be changed by external control. The protocol is used by Monark Exercise's softwares and some external controllers that are prepared to fully benefit from the advanced capabilities of the bike.

### 2: Ergoline compatible (recommended for "er900")

The command type is used when the bike is controlled by an external device that uses Ergoline's "er900" protocol, baud rate is locked to the 4800. If the external device "asks" the bike about current power, the bike responds with the set power. This setting is recommended before the command type 3 which removes the risk of the device trying to "chase" a value.

### 3: Ergoline compatible (alternative)

The command type is used when the bike is controlled by an external device that uses Ergoline's "er900" protocol, baud rate is locked to the 4800. If the external device "asks" the bike about current power, the bike responds with the set power.

### 4: 839 compatible

This command type is very similar to command type "0", the only difference is that if an external device requests the ID, the bike responds as if it was an 839-bike of newer model. The setting is used for older external control devices that are not yet adapted to NOVO series ("backwards compatible").

All commands for external devices are active regardless of the command type that is selected in addition to the small differences presented above. The parts in Ergoline protocol that handle blood pressure and its parameters are not implemented.

The two free ports can have different settings.

When connecting to multiple devices, it is important to ensure that one device does not sets a new target without the other devices note it (master - slave).

## Command type settings

Default for the two free ports is command type 0, which will work in most cases. If you need to change it you can do it in settings in terminal mode in the Monark Exercise software.

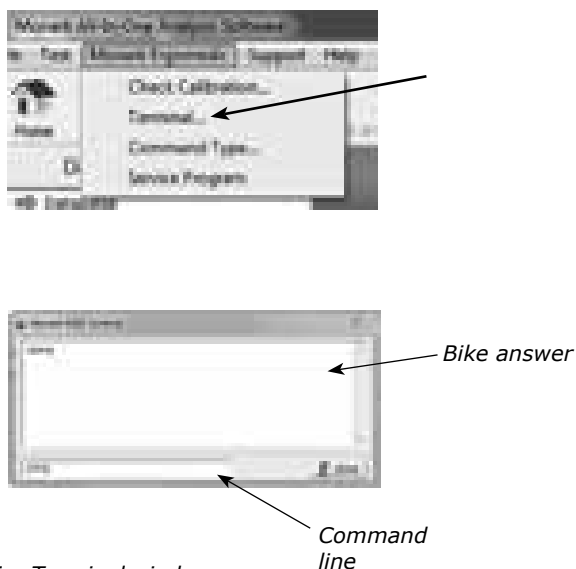


Fig: Terminal window

Ensure that you are connected to the bike. Type *ping* in the command line in the window. Then the bike beep once and answer *pong* in the text window above the command line, see *Fig: Terminal window*.

You can set the command type for both ports regardless of which port the bike is connected to. Use the following commands:

- `cmdtypers232 #` and press ENTER to set the RS232 port to the command type #, where # is 0, 2, 3 or 4
- `cmdtypeusb #` and press ENTER to set the USB port to the command type #, where # is 0, 2, 3 or 4

If you only send the command `cmdtypers232` alternatively `cmdtypeusb` without digit, the bike responds with the current command type (0, 2, 3 or 4) for the connection.

## Set command type for the RS232 port

When power is turned on to the bike gives an indication of what command type the RS232 port is set to. First, a long beep followed by the same number of short beeps is the command type settings for the RS232 port. In default ("0") you do not hear a short beep, but at normal Ergoline setting ("2"), you hear two short beeps after the long beep.

- 0 — A long beep
- 2 — A long beep followed by two short beeps
- 3 — A long beep followed by three short beeps
- 4 — A long beep followed by four short beeps

## Monark test software

Monark test software is available for free download from our website: [www.monarkexercise.se](http://www.monarkexercise.se). If you use a PC with touch screen, we recommend you to also download the *Monark Touch* software which is adapted for that type of screens with a custom graphics with larger and clearer buttons.

Insert the desired cable between the bike and the computer and start the PC software. Normally the bike and computer connect automatically. If not, read the software reference information or contact software support by writing an email in English to the software developer HUR Labs support: [support@hurlabs.com](mailto:support@hurlabs.com).

## Other external PC software

Other external PC software that is compatible with the bike can also be used. Normally you have to choose the correct COM port in the PC software. See the PC software manual.

## Terminal mode PC

A variety of settings can be made from the software. For more information about this see the software's help file.

Settings can also be made directly from the PC through the terminal mode, see the **Technical Manual** which is available from Monark Exercise AB.

# Monark novo display unit

## Via the display, you can perform manual training with full precision and performance!

With Monark novo display unit, you can control the bike via the touch screen. The display shows the current rpm, time, power and pulse (if any heart rate monitor is used).

You can also set up target based training regarding distance, time and calories. If you want to do fitness tests, etc., you can download Monark test software to your PC from our website, [www.monarkexercise.se](http://www.monarkexercise.se), and then connect your PC to Monark novo control unit on your bike.

### Start training

The display will start automatically after you have turned on the power to the bike.

Then the display shows the Start view. Now if you want to start, press the "Start" button, the display will show normal mode and the time starts counting.

If autostart is enabled, the time starts count ten seconds after you have started to pedalling, without you have to press "Start". Autostart is set in "Settings general".

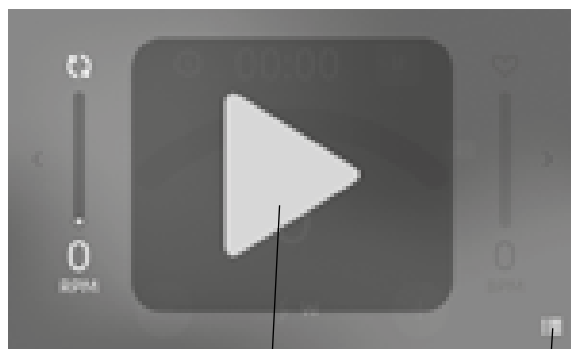


Fig: Start view

#### NOTE!

To change workload the rpm has to be at least 30. If rpm is lower, the value is displayed in red. It returns automatically to normal view when rpm is more than 30.

If you want to change the type of workload and the unit, press the icon for the current selection, see section "Workload control".

This is "Normal mode" that can be displayed in two versions, complete and simple. You can switch between them by pressing the arrow keys (change screen) in the middle of the short sides on the display.

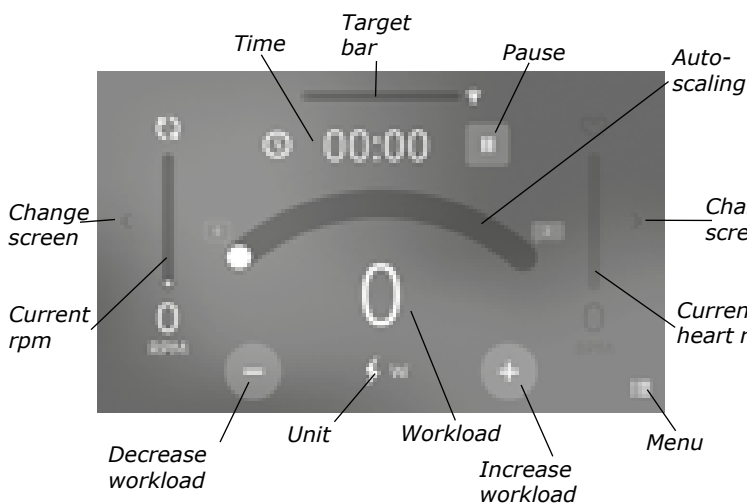


Fig: Normal mode, complete

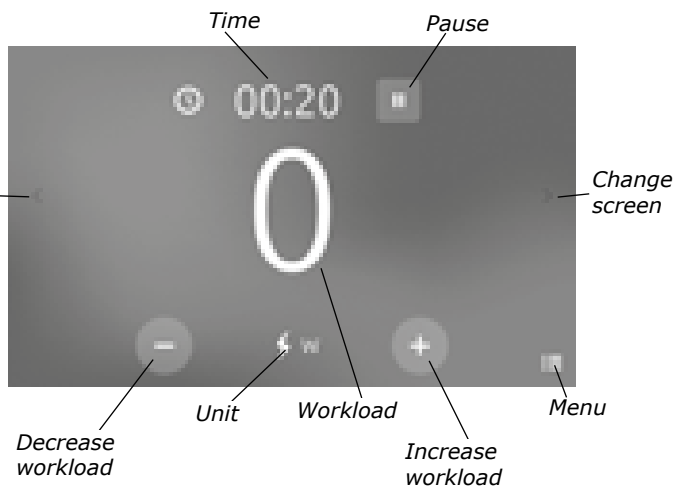


Fig: Normal mode, simple

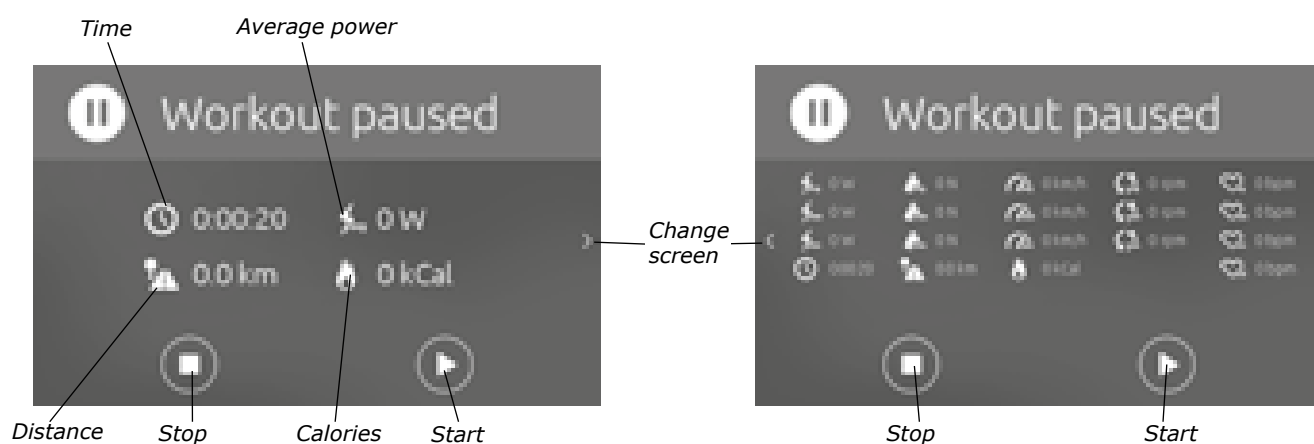
## Stop / pause training

If you want to stop training, press "Pause" or just stop pedalling. After you have pressed "Pause", or about 10 seconds after you have stopped pedalling, the display is changed to "Workout paused", and the workload goes down to "base power".

If you wish to continue the already initiated training, press "Start" and time counting is continuing and the workload returns to the last value. To cancel press "Stop" and the display is reset.

Below you can see how the results is displayed, and you can switch between the two different views by pressing the arrow keys (change screen).

The results can be displayed in both km and km / h or miles and mph, depending on what you selected in the "Settings general" (Metric units: Yes / No).



Average power	Average workload	Average speed	Average rpm	Average heart rate
Max. power	Max. workload	Max. speed	Max. rpm	Max. heart rate
Min. power	Min. workload	Min. speed	Min. rpm	Min. heart rate
Total time	Total distance	Calories		End heart rate



### Interval training

Use "Start" and "Pause" to do interval training!

Cycling and select the workload you want, press "Pause" and the bike releasing the workload. Then press "Start" and the bike put on the workload again. The time is not reset, it continues counting.

## Workload control

If you press the symbol for unit a menu appears, "Set unit", where you can change which workload unit you want to use.

The workload unit you can choose is: l / min, kpm / min, Watt, Newton and kp.

- Rpm-independent**
- l / min (calculation, see below)
  - kpm/min
  - Watt

**NOTE!**

The text turns red when the set power not can be reached with the current rpm with maximum workload. Please reduce the workload level or pedalling faster (increase rpm) until the text turns white again.

- Rpm-dependent**
- Newton
  - kp

When you have chosen which workload unit you want to use, the display returns to "Normal mode". If you press "Home" the display returns to normal mode without any changes.

If you press "Locked mode" in the view "Set unit" you lock the display to show only the current rpm instead of the current workload, see *Fig: Locked mode*. You can also choose to display only the current rpm with only a digit, see *Fig: Locked mode, simple*. To cancel the "Locked mode", press the "Locked mode" and then you will return to "Set unit". There you can choose optional workload unit. When you have chosen unit the display returns to normal mode.

If you are in the "Locked mode", press "Menu", you can choose "Settings pulse" or "Settings general", see further details under each title. .

You can always, even during training, change control mode.

**Calculation l / min:**

Monark novo display unit uses a formula to calculate VO<sub>2</sub> at different workloads.

This is according to Astrand's table between 150 W and 300 W, and a good approximation for 15-700 W and a cadence of about 50-65 rpm.

**These values should only be seen as an indication to meet Åstrand, for more information see current literature!**

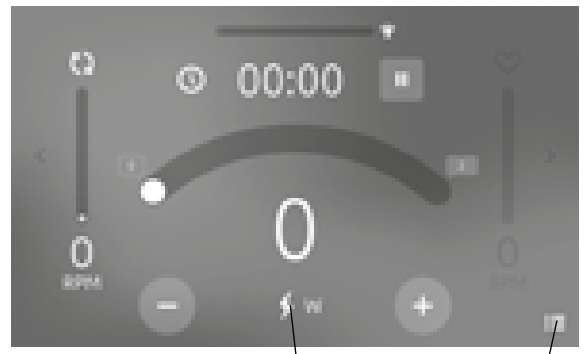
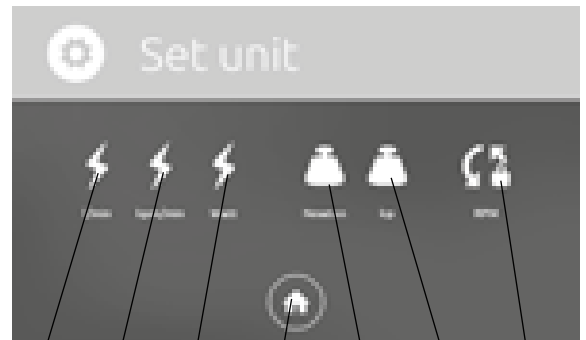


Fig: Normal mode Unit Menu



l/min kpm/min Watt Home Newton kp Locked mode

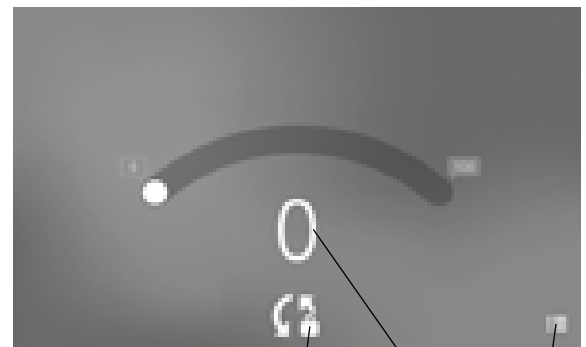


Fig: Locked mode Locked mode Current rpm Menu

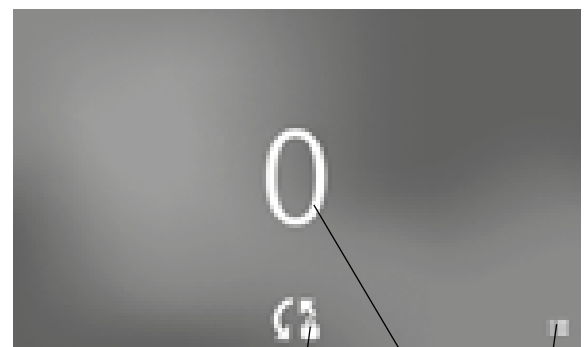





Fig: Locked mode, simple Locked mode Current rpm Menu

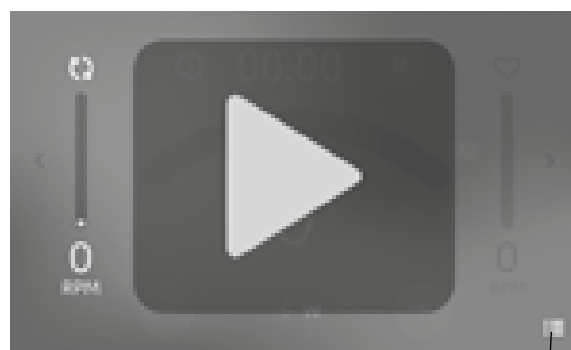


## Menu

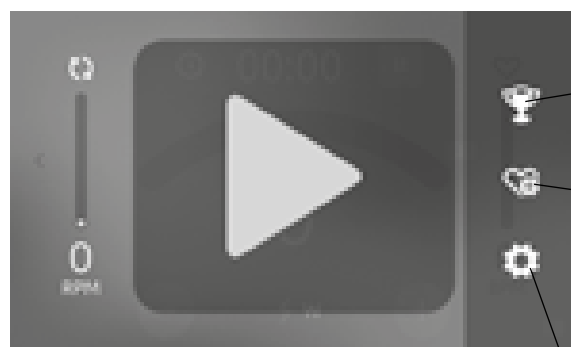
In the display is a menu where you can make different settings. You can find it by pressing the Menu icon. Then a menu is showed to the right in the display where you can select the following:

-  Set a target  
(Set target)
-  Heart rate settings  
(Pulse settings)
-  Settings general  
(Settings)

You can at any time during the training open the menu to e.g. search for a heart rate monitor.



Menu



Target

Heart rate

Settings

## Set a target



Here you can do your settings if you want to exercise against a specific target - distance, time or consumed calories.

If you want to train for a specific distance, a specific time or a specific amount of calories consumed, set the value and then the bike counts down / up.

When you train against a specific target, a "target bar" is showed in the display. It shows how far you have left until your set target has been achieved.

The figure below is displayed when you choose "custom" no matter what target you want to set up. When you press the arrow up increases the value from 1, when you press the arrow down decreases the value from 9. At the same time, the value that appears above "home" is changed to show the value you set.



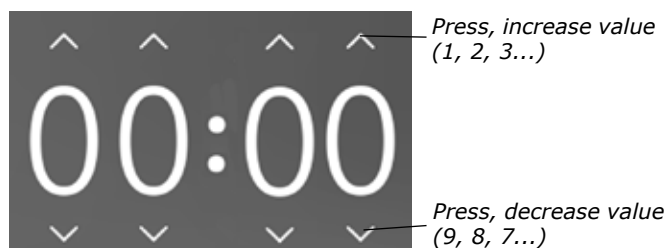
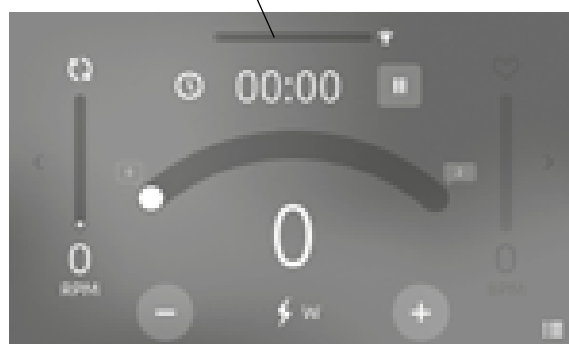
Distance

Home

Time

Calories

Target bar



## Set distance target

Here you can choose how long distance you want to train. There are some preset distances, but you can also select "custom" and then you choose a distance. The distance can be displayed in both km and miles, depending on what you selected in the "Settings general" (Metric units: Yes / No).

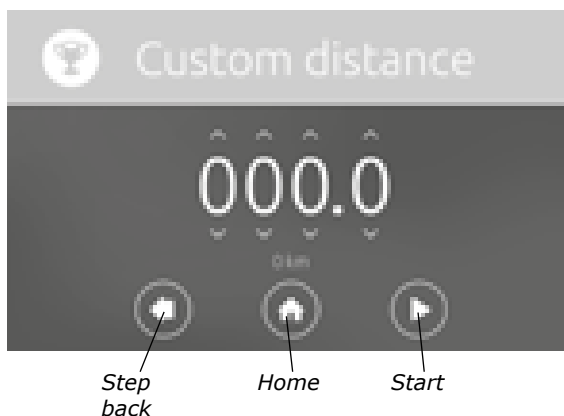
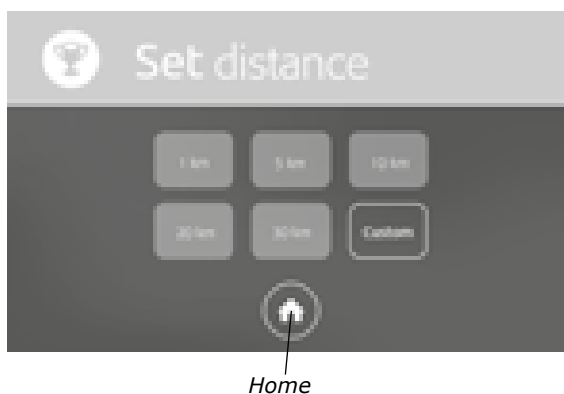
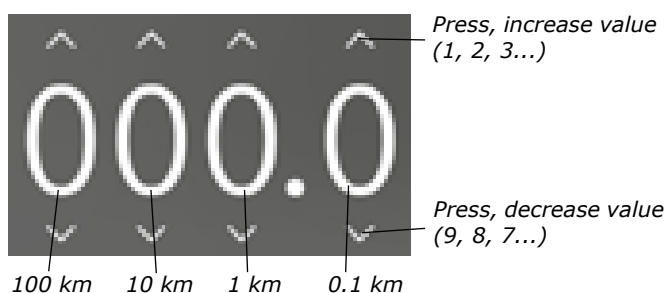
The distance is not exactly, but it is a calculation:

50 rpm = 20 km / h, others rpm linear.

1 rpm  $\longleftrightarrow$  2/5 km / h

1 km / h  $\longleftrightarrow$  5/2 rpm

"Target bar" appears in the display.

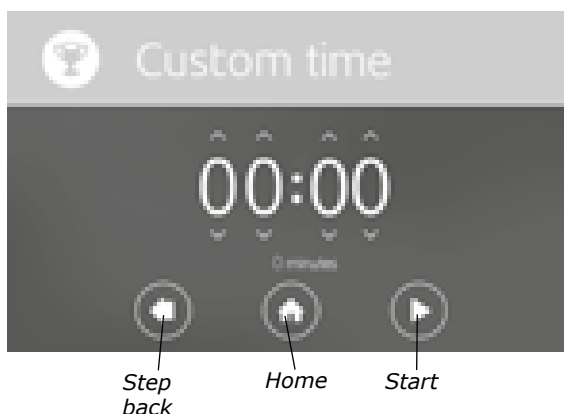
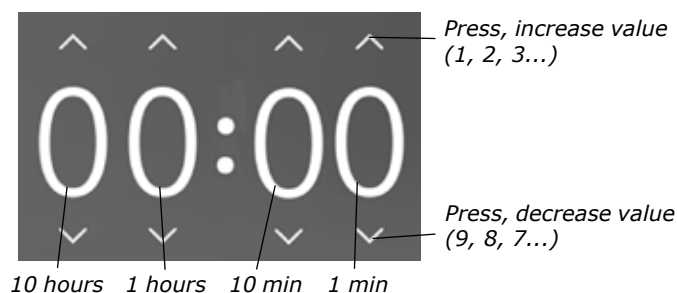


## Set time target

Here you can choose how long time you want to train. There are some preset times, but you can also select "custom" and then you choose how long time you want to train.

The time in the display will count down to zero.

"Target bar" appears in the display.



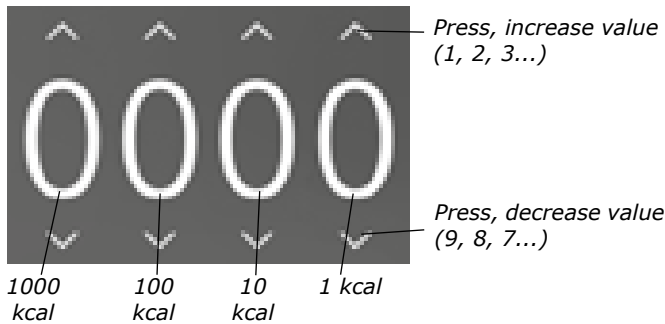
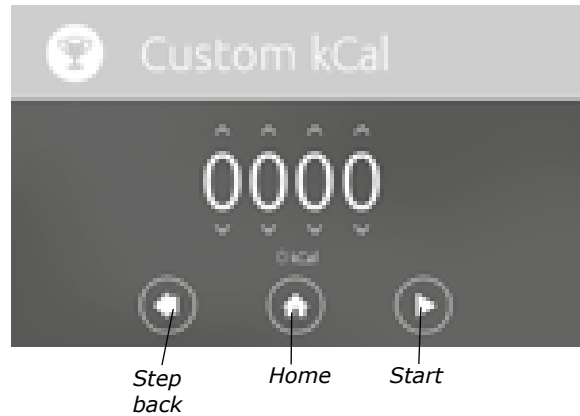
## Set target in kCal

Here you can choose how many calories you want to burn during your training. There are some preset values, but you can also select "custom" and then you choose how many calories you want to burn during your training.

"Target bar" appears in the display.

As a standard calculation, when we display calories on our calibrated bikes, we use: 1 minute with 100W gives 7 kcal.

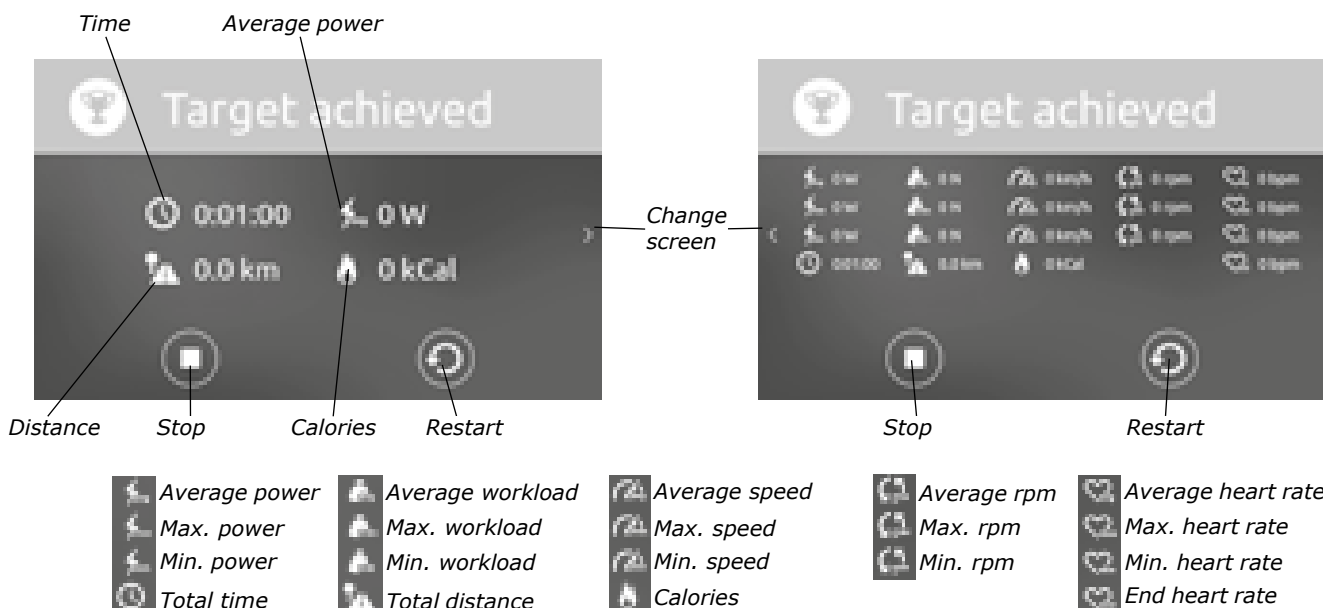
We have chosen the calculation above, which we believe is consistent with what the body consumes during a normal cycle position (not the "consumption" on the flywheel).



## Exercise target achieved

When you have achieved your target, the display shows "Target achieved". There can you can see your results, and you can switch between the two different views by pressing the arrow keys (change screen).

The results can be displayed in both km and km / h or miles and mph, depending on what you selected in the "Settings general" (Metric units: Yes / No).



## Pulse settings



Here you can choose what heart rate standard you want the bike to search for, Bluetooth SMART, ANT+ or both.

The person's heart rate ("pulse") can be measured by, for example, a chest belt that detects your pulse from your heart and sends the pulse to the bike with Bluetooth SMART or ANT+ technology.

### Bluetooth SMART

When the bike and a Bluetooth SMART heart rate monitor have been paired the heart rate monitor Bluetooth ID and the current heart rate is displayed at "Pulse". You can choose to actively lock the heart rate monitor by pressing "Lock". Then the bike is only searching for that particular heart rate monitor. Press "Reset" if you want to release the lock to only a specific heart rate monitor and lock with a new or continue to search freely.

You can use several Bluetooth SMART heart rate monitors to the bike, but you can only lock to one at a time.

The bike locks to the heart rate monitor that it finds first (within 10 m). If more heart rate monitors are used, we therefore recommended to lock into a specific Bluetooth ID to ensure that the correct heart rate appears.

#### NOTE! (for Bluetooth SMART)

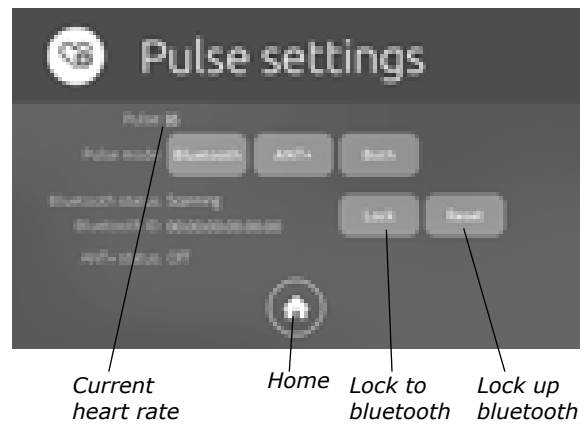
It must be ensured that no other belts in addition to the belt that should be paired to the bike is active OR that any other device (cell phone, bike computer, etc.) that could connect to the belts are active during the process!

### ANT+

(ANT+ is always active)

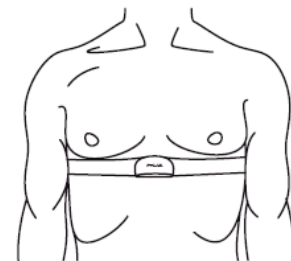
ANT+ uses "proximity pairing" which means that you should be close to the display for it to start listening to it. When the display and the heart rate monitor is paired, you can be relatively far from the bike with retained function. This process ensures that the display is listening on the correct belt.

If you have connected to an ANT+ heart rate monitor it says "connected" at "ANT+ status:" and the current heart rate is displayed at "Pulse".

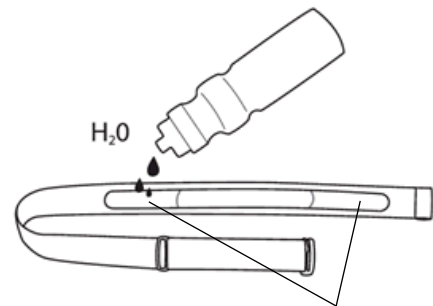


### If you use chest belt

Heart rate registration requires that the heart rate monitor is positioned correctly. When it is correctly fitted the logo on the belt will be central and readable, outward and upright, by another person. Before putting on the belt, clean the skin where the belt is to be placed. The chest belt should be secured at a comfortable tension around the mid section, just below the breast muscle, see *Fig: Placement chest belt*. Moisten the electrodes before use, see *Fig: Moistening the electrodes*.



*Fig: Placement chest belt*



*Fig: Moistening the electrodes*

*The images above are used with permission of Polar Sweden.*

## Settings general



### General settings

Here you can make the following settings:

Autostart: Yes/No  
Yes: time count and training will start automatically when you start pedalling No: you must press "start" before the time count and training starts

Metric units: Yes/No  
If you choose Yes units are shown in km, if you choose No the units are shown in miles

Start screen: Last used  
(not activated) Standard  
Single value

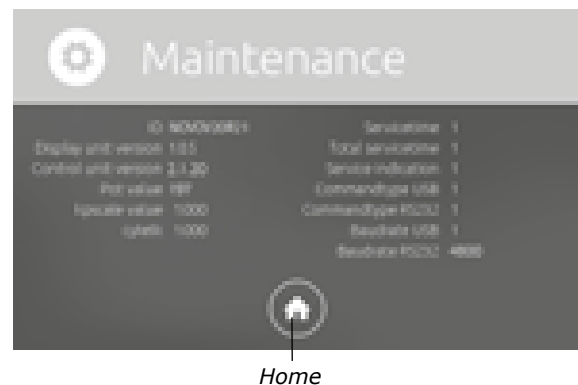
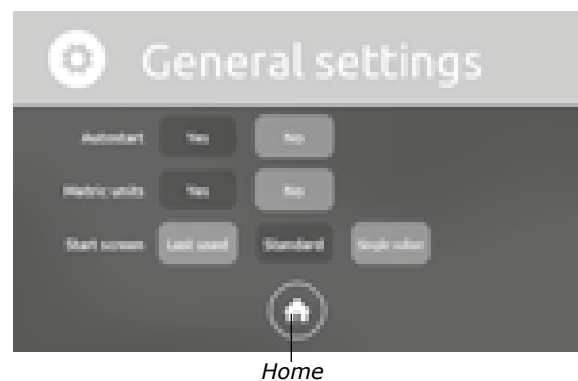
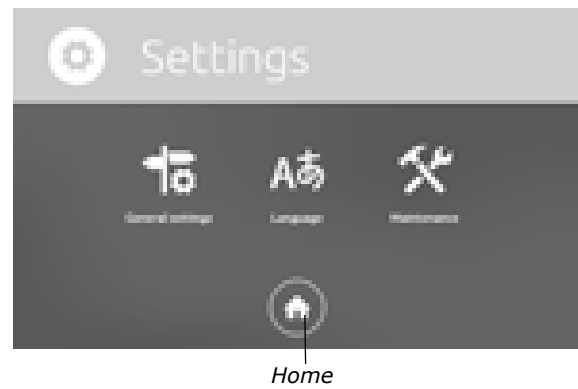
### Language

Not activated

### Maintenance

Service and maintenance. This is mainly used by service personnel.

ID: Device ID (control unit)  
Display unit version: Display software version  
Control unit version: Control unit software version  
Pot value: Potentiometer value  
kpscale value: The value displayed on the pendulum scale, if available, read braking force.  
cykelk: Cycle constant  
Servicetime: Time in use since last service (hours with rpm)  
Total servicetime: Total time in use (hours with rpm)  
Service indication: 0 = indicator inactivated  
1 = maintenance service completed  
3 = maintenance service recommended  
Commandtype USB: Command type USB port  
Commandtype RS232: Command type RS232 port  
Baudrate USB: Data transfer rate USB port  
Baudrate RS232: Data transfer rate RS232 port



## Connect Bluetooth SMART heart rate monitor (Monark novo control unit)

The bike has a module that can connect to the Bluetooth SMART compatible heart rate belts or similar devices designed to this standard. The standard includes no distance function so we recommend different procedures depending on whether there is only one heart rate monitor or there may be several within the range of the receiver (10-15 m).

### Connection to chest belt with solitary bike (pulse mode 2) STANDARD

This works when you only have one bike with Bluetooth SMART and other monitors with this standard within the receiver range, normally 10-15 m.

The bike is set by default to automatically connect temporarily with the first active heart rate monitor with Bluetooth SMART technology that comes within the range. The bike is paired with this monitor until the signal is dropped. Heart rate monitors tend to stop transmitting within 30 seconds to two minutes from the time they lose pulse contact or have been taken off. As soon as a signal is dropped, the bike begins to search for another heart rate monitor (new or old).

You can use several heart rate monitors on the same bike but it may only activate one monitor at a time (within range).

#### NOTE!

Electromagnetic waves can interfere with pulse function when wireless chest belt or similar is used. Cellular phones or similar are not allowed to be used near the bike during test.

In case of problems, turn off WiFi, Bluetooth and similar on computers nearby.

## Connection to heart rate monitor with several bikes (pulse mode 3)

In a room with several bikes or other devices that also use Bluetooth SMART heart rate monitors, every bike should be locked to a specific heart rate monitor so you have control of which is connected to which bike.

This can be done in Monark novo display unit (further information in section "Monark novo display unit") or in Monark test software or similar.

Open the terminal window. Ensure that you are connected to the bike. Type *ping* in the command line in the window and press *Enter*. Then the bike beep once and answer *pong* in the text window above the command line, see *Fig: Terminal window*.

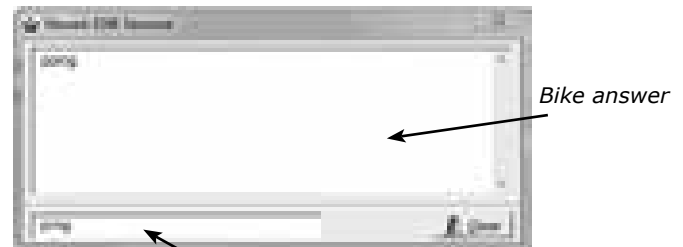
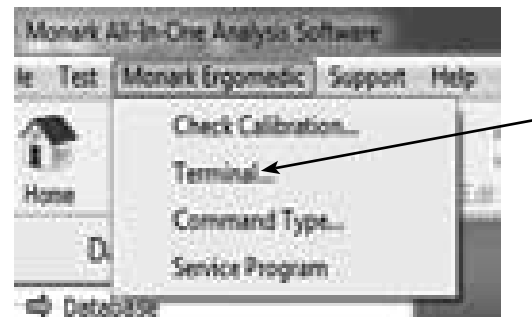


Fig: Terminal window

## NOTE!

It must be ensured that no other belts in addition to the belt that should be paired to the bike is active OR that any other device (cell phone, bike computer, etc.) that could connect to the belts are active during the process!

Activate the belt by someone wearing it as instructed and standing near the bike. Write *pulsemode 2* in the terminal window to ensure that the bluetooth system is active. Then let the the bike pair automatically with the belt. Write repeatedly *pulseble*, and press *Enter* after each, in the terminal window until the bike corresponds with the current pulse value, which means that the belt is paired. Write *pulseble lock* to lock to the active belt. With this the bike is locked only against this belt and will ignore all others which may be within reach. Write *pulsebleid* in the terminal window and the bike will respond with the belt's complete id. Note this on the belt together with which bike the belt / transmitter unit is locked to for later reference. To check what id which is locked to the bike, type *pulsebleid* in the terminal window and the bike responds.

Alternatively, if you already know the belt's complete id, you can direct lock it. The complete ID has the format `##: ##: ##: ##: ##: ##`. Sometimes the device ID is printed on the transmitter housing or packaging but different types of abbreviated notation appear on, for example Polar chest belts. There are many free applications for BLE SMART HR which can be used to see the belt ID in the cell phone or PC tablet. Then you can lock directly to the belt without having it active by typing the command *pulsebleid "##: ##: ##: ##: ##"* in the terminal window and this will register and lock to the specified id (note that it should be " " around the id).

If you want to return to automatically pair with the first compatible belt within reach, you write the command *pulseble break* or *pulsemode 2*

There is a risk that the "dedicated" belt may pair with another device before it is paired to the bike if the other device is within range (eg app in cell phone, etc.). Therefore, we recommend that, if possible, all devices with Bluetooth SMART are locked to specific monitors so that this does not happen. If a heart rate monitor has paired with the wrong device, turn it off and let it lie for a while so it shuts itself down. The time depends on the brand, but it usually varies between 30 seconds and 2 minutes. Then the belt is reset again. A belt can only pair with one device at a time and it is often enough just to reach the electrodes to make it active.

In environments where you want to change test persons without wash and dry the belt first, you can use so-called textile belts where the transmitter unit sits with quick couplers on a fabric belt with electrodes. Then you can use several textile belts but only a transmitter unit per bike and change into dry belts quickly by moving the transmitter unit which is locked to the bike. The transmitter unit is often easy to wipe clean. In this way you can maintain good hygiene when the tests are close together.

Monark Exercise AB has tested several belts, both of famous brands and so-called "no-name". As long as they follow the **Bluetooth SMART** standard they work on the bike, but we strongly recommend that you use well-known brands such as Polar, because "no-name" belts in many cases have been shown to have both very poor function and range.

# Calibration

Calibration is necessary so that the electronic and the mechanical parts of the cycle conform. The work carried out on the bike is a result of the braking force (pendulum mode) and the number of pedal revolutions (= distance). The effect is then counted out by dividing the work done by the time it took to accomplish it. Validation includes both mechanical and electronic procedures.

## Calibration pendulum

All RC6 novo are calibrated in the factory, but a calibration of the pendulum can still be done to verify this. If so, please do the following.

Open the front cover. Check that the brake belt (3) is loose. If not, move the pendulum to 4 kp and hold it there a while to loosen it. Check that the pointer on the pendulum is in line with the scale 0-index, see section "Scale adjustment", adjust very precisely if necessary.

Calibration weight 4 kg (Art. No: 9000-211) is hung on the balancing spring parallel to the brake belt.

### NOTE!

The flywheel must be completely stopped before the weight is hung on!

This weight (4 kg) can, when properly adjusted, be read at the corresponding point on the scale. If there is a deviation, adjust the pointer to the correct position by adjusting the weight (2) inside the pendulum. To change the adjustment weight loosen the adjustment screw (1). Should the index of the pendulum weight be too low, move the adjusting weight upwards in the pendulum, and if the index should be too high the adjusting weight is moved somewhat downwards and locked in the new position. Lock the adjustment screw in the new position. This process is repeated until pointer is in the exactly correct position. Close the front cover when everything is done.

### NOTE!

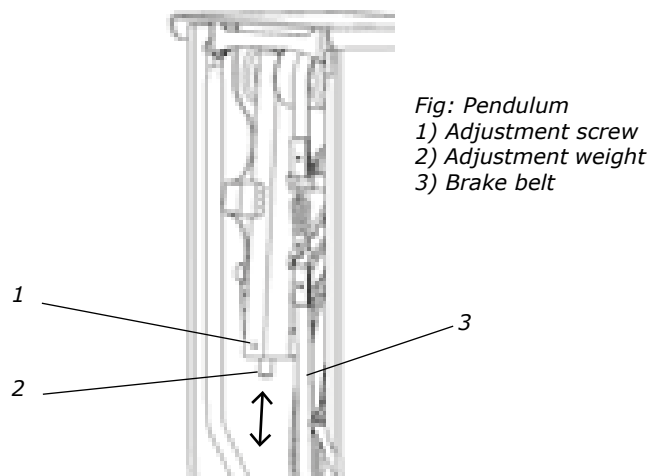
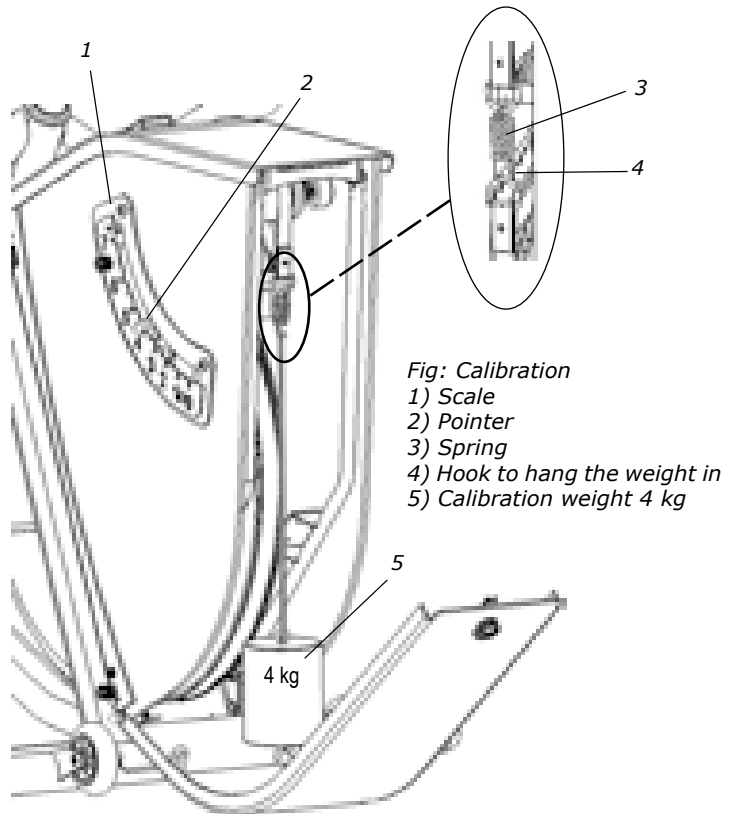
It is important that you are very precise when you adjust or reset the scale.

Check the calibration of the pendulum once a year or when needed.

## Calibration electronics

Usually it is not necessary to recalibrate the cycle electronically, but it should be done after each service, change of electronic part, movement or if you adjusted the 0-index.

The calibration coefficient calculated by the computer is stored in main memory. No matter when the power is turned on, the last stored calibration will be placed in main memory. New calibration automatically replaces the old.





## Electronic calibration - with the pendulum

The best way to calibrate electronically is with the pendulum directly at start up.

The following steps show how the electronics are calibrated against the pendulum.

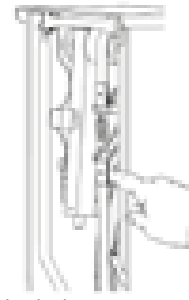
1. Open the front cover.
2. Check that the brake belt is loose on the flywheel, see *Fig: Checking loose brake belt*. If not, move the pendulum to 4 kp and hold it there a while to loosen it. Move the pendulum pointer to 0 again, and check again that the brake belt is loose.
3. Adjust the scale, see "Adjustment / reset scale", so that the pendulum pointer is pointing at the 0-index of the scale, see *Fig: Zero position*.
4. Turn off the power to the bike and move the pendulum pointer to 6 kp, as shown in *Fig: 6 kp*.
5. Hold the pendulum pointer at 6 kp and turn on the power to the bike again and wait for a beep. Keep left the pendulum at 6 kp and after about 5 seconds you will hear 10 rapid beeps. Move the pendulum pointer to 0, see *Fig: 0 kp*. Wait for a beep.
6. Move the pendulum pointer to 2 kp, see *Fig: 2 kp*. Wait for a beep.
7. Move the pendulum pointer to 4 kp, see *Fig: 4 kp*. Wait for a beep.
8. Move the pendulum pointer to 6 kp, see *Fig: 6 kp*. Wait for a beep. Move the pendulum to 0 again.

The value at each point is stored at the end of each beep. New value is checked against a table of acceptable range. If there are any values outside the acceptance window you will hear three short beeps directly in connection with each calibration point and the calibration will not be used (the last previous stays).

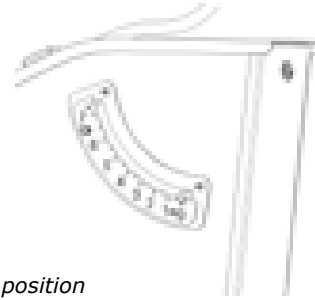
Calibration is complete if no error messages or beeps are received. Close the front cover.

### NOTE!

The pendulum must be kept still at the different positions. This is done by pressing down the pointer into the groove on the scale at each kp value. It is also important to keep left the pendulum at each point until the beep stops before moving to the next position.



*Fig: Checking loose brake belt*



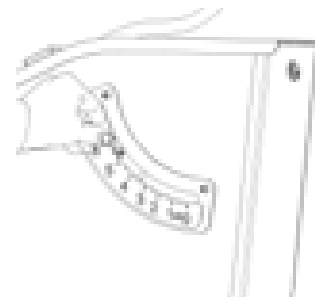
*Fig: Zero position*



*Fig: 2 kp*



*Fig: 4 kp*



*Fig: 6 kp*



*Fig: 0 kp*

## Testing with RC6 novo

The versatility of the RC6 novo enables it to be utilized in a variety of testing environments. The bike is however designed, and will be at its best, in physiological tests in sports medicine.

In general, one should note that stresses on the tested person can become quite severe, whether in a clinical work test or a simple fitness test in physical activity contexts. As a precaution, it may be advisable, prior to beginning an exercise protocol, that each test person consults with a physician.

Before testing, the test manager should review the entire protocol operation with the test person, explaining the work which will be required and the duration of the procedure. One should also agree on how the test person shall give signs of any fatigue, chest pain or other abnormal physical reactions.

The test person should not engage in heavy physical activity for several hours prior to testing to establish maximum oxygen consumption. In addition, all testing should be performed a reasonable time after meals. The test person should refrain from smoking within an hour of the testing period.

The test person should also wear suitable clothes. Training suit or loose-fitting clothing is best. More detailed instructions are rarely needed, regarding the ride, but it may still be appropriate for the test leader to give some advice on pedalling, saddle height and position of the handlebars. It should be comfortable to ride. Seat height should be set so that when the ball of the foot rests on the pedal the knee should be slightly bent when the pedal is in its lowest position.

Let the test person pedal at a low work load to experience how it feels to hold a steady RPM.

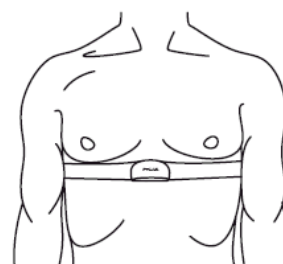
Finally, the chest belt shall be put on, see *Fig: Placement chest belt* for correct placement. Check for a minute that a proper heart rate is displayed. If you know the test person's normal heart rate you may also determine how nervous he / she is prior to the test. It may be appropriate to let the test person rest long enough before the test so a more or less stable resting heart rate can be read.

## Test person enforcement

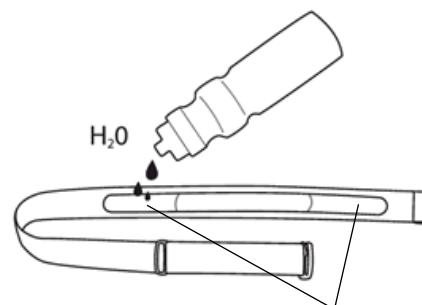
The bike performs automated tests virtually by itself, requiring minimal intervention by the test operator. This allows the operator to pay careful attention to the test person without distraction. The response to the exercise protocol can be accurately estimated and appropriate action taken to assist the test person, if necessary. Some programmes have sections where the test person may develop significant physical effort. The effect on the test person can not be underestimated.

During the test it is important to observe the test person's appearance and heart rate. The testing should be stopped immediately if the test person reports chest pain, difficulty in breathing, etc. A system of prompt medical attention should be set up prior to testing, in case of emergency.

The test person may also have difficulty in keeping a steady pedalling speed. This is of minor importance (except in cases where the program assumes a constant braking force, since the effect is automatically adjusted to the correct value as long as the pedal speed is at least 30 RPM). However, it is important to consider what each test documentation says about the pedal speed.



*Fig: Placement chest belt*



*Fig: Moistening the electrodes*

*The images above are used with permission of Polar Sweden.*

## Reviewing results

The maximum oxygen uptake is a standard measurement of the condition of the heart- and lung-functions. Dependent on the linear relationship between work and oxygen uptake and between work and heart rate, the heart rate response to work may be used to estimate the oxygen consumption. If the maximum heart rate is considered, the maximum oxygen consumption may be determined.

The YMCA and Åstrand protocols estimate the maximum oxygen consumption, based on a submaximal workload while all others report the oxygen consumption required by the final workload.

The estimated maximum oxygen consumption derived from some of the ergometer tests is subject to the error of the “age related predicted maximum heart rate“. Although there is a definite and linear relationship between work and oxygen uptake, there are some differences in actual oxygen uptake based on individual work efficiency. Test persons who are less familiar with bike exercise and those individuals who are less fit, are more likely be less efficient than those who ride bikes frequently.

It should be noted that these results are estimates or predictions of maximal response and have a greater chance of being in error than if the individual were tested to their actual maximum value. Interpretation should therefore be made more carefully with an understanding of the possibility of errors in the methodology.

### Power calculation

1 RPM = a point on the flywheel moves 6 meters per minute.

50 RPM = 300 m / min

2 kp force gives  $2 \times 300 = 600$  kpm / min

100 RPM = 600 m

1 kp force gives  $1 \times 600 = 600$  kpm / min

Exact calculation:

Watts = RPM x kp x 0.98065

"Rule of thumb" calculation:

Watts = RPM x kp

(2% error, but may be good enough in many cases)

# Troubleshooting guide

Symptoms	Probable Cause / Corrective Action
LED does not light up	<ul style="list-style-type: none"> <li>• No current in the wall outlet. Check the fuses.</li> <li>• Power switch off on the bike / Monark novo control unit.</li> <li>• Correct power adaptor? Check that the power adaptor information (voltage, current, polarity, AC / DC) in section "Product information" complies with the power adaptor which is used.</li> <li>• Check cables and connections.</li> </ul>
No connection to PC	<ul style="list-style-type: none"> <li>• Check cables (connections and type)</li> <li>• Right "cmd type", see section "Connection to controller"</li> <li>• Right COM-port (PC software or similar).</li> <li>• Drivers missing when using the USB-serial adaptor</li> </ul>
No workload	<ul style="list-style-type: none"> <li>• Pendulum is stuck. Contact service centre for action / replacement.</li> <li>• Check that the pedal speed is higher than 30 RPM and recorded. No workload is put on if the actual pedal speed is lower than 30 RPM. See in Monark test software: - 'Monark Ergomedic' - 'Service program...' - 'Service Setup...' - 'Pedal measurement'. The default setting is 30 RPM but can be adjusted to the desired value.</li> <li>• Check calibration.</li> <li>• Check that the brake belt is suspended in the spring and located right on the flywheel.</li> </ul>
No heart rate displayed	<ul style="list-style-type: none"> <li>• A chest belt is already connected and active at the moment to other device.</li> <li>• Check that the battery is alright in the chest belt, moisten your thumbs and click on the electrodes, a low clicking sound will be heard at the battery cover, (not chest belts with Bluetooth technology) alternatively that the heart rate is displayed in the PC software.</li> <li>• If no pulse is not detected despite new battery, try to take the battery out from the chest belt transmitter and let it be out for six minutes. If it does not work anyway, contact your dealer.</li> <li>• Make sure the belt fits correctly on the test person, see <i>Fig: Placement chest belt</i> in section "Pulse settings", and that the strap is sufficiently tightened. Moisten the electrodes, in severe cases it may be necessary to use gel alternative, one drop of dish washing liquid mixed in water. Pulse signal strength varies from person to person. Try the belt with a person known to have a good pulse wearing a chest belt.</li> </ul>
Irregular heart rate	<ul style="list-style-type: none"> <li>• Use an external device (eg. pulse clock or an app in the cell phone) to check if it also has an irregular pulse. If this is the case, there is probably disturbance in the room. The disturbance may be electronic fields from power cables, elevators, lamps etc. or other electronic devices which are too close (eg. cell phones). Move the bike to a different location in the room or change rooms. Even synthetic fabrics can create static electricity that interferes with heart rate signal. If the HR remains irregular at work the person's health should be examined.</li> </ul>
No RPM reading	<ul style="list-style-type: none"> <li>• Check cable.</li> </ul>

# Troubleshooting guide

Symptoms	Probable Cause / Corrective Action
Unable to calibrate force	<ul style="list-style-type: none"><li>• The potentiometer shaft is not attached to the pendulum shaft, tighten the screw.</li><li>• Check the potentiometer so that it is not misadjusted. See the computer software menu - 'Monark Ergomedic' - 'Service program...' - 'Potentiometer' and follow the instructions that appear on the screen. Then calibrate the electronics again.</li></ul>
There is a click noise when pedalling (increases with the weight)	<ul style="list-style-type: none"><li>• The pedals are not tight. Tighten them or change pedals.</li><li>• The crank is loose. Check, tighten.</li><li>• The base bearing is loose. Contact your dealer for service.</li></ul>
Scratching sound is heard when pedalling	<ul style="list-style-type: none"><li>• Check that no material scrapes against the crank - chain - wheel - except the brake belt.</li></ul>
There's a click noise and a squeak noise when pedalling	<ul style="list-style-type: none"><li>• Loosen the chain.</li><li>•</li></ul>
Problems with the computer software	<ul style="list-style-type: none"><li>• Describe the problem in an email (write in English) and send it to the software developer HUR Labs support, support@hurlabs.com.</li></ul>

# Service and Maintenance

Note that the text about service and maintenance is universal and that all parts may not be relevant to your bike.

## NOTE!

Make sure the voltage indicated on the appliance corresponds to the local mains voltage before making connections.

## Warranty

### EU countries - Private use

If you are a consumer living in the EU you will have a minimum level of protection against defects in accordance with EC Directive 1999/44/EC. In short, the directive states that your Monark dealer will be liable for any defects, which existed at the time of delivery. In case of defects, you will be entitled to have the defect remedied within a reasonable time, free of charge, by repair or replacement.

### EU countries - Professional use

Monark Exercise products and parts are guaranteed against defects in materials and workmanship for a period of one year from the initial date of purchase of the unit. In the event of a defect in material or workmanship during that period, Monark Exercise will repair or replace the product. Monark Exercise will not, however, refund costs for labour or shipping.

### Other countries

Monark Exercise products and parts are guaranteed against defects in materials and workmanship for a period of one year from the initial date of purchase of the unit. In the event of a defect in material or workmanship during that period above, Monark Exercise will repair or replace (at its option) the product. Monark Exercise will not, however, refund costs for labour or shipping.

# Service check and Maintenance

It is important to carry out a regular service on your ergometer, to ensure it is kept in good condition.

Always keep the bike clean and well lubricated.

## Service action:

- We recommend isopropyl alcohol to disinfect the surface of the bike. Use a damp but not wet cloth to clean the surface you wish to disinfect.
- Surface treatment with a rust inhibitor, especially when the bike is clean and the surfaces are dry. This is done to protect the chrome and zinc parts as well as the painted parts (4 times per year).
- Check now and then that both pedals are firmly tightened. If not the threading in the pedal arms will be damaged. When the ergometer is new it is important to tighten the pedals after 5 hours of pedalling (check this 4 times per year).
- Check that the pedal crank is secure to the crank axle (4 times per year).
- Be sure that the pedals are moving smoothly, and that the pedal axle is clear of dirt and fibres (4 times per year).
- When cleaning and lubricating be sure to check that all screws and nuts are properly tightened (twice a year).
- Check that the chain is snug and there is no play in the pedal crank (twice a year).
- Check that pedals, chain and freewheel sprocket are lubricated (twice a year).
- Be sure that the brake belt does not show significant signs of wear (twice a year).
- Check that the handlebars and seat adjustment screws are lubricated (twice a year).
- Be sure that all moving parts, crank and flywheel are working normally and that no abnormal play or sound exists. Play in bearings causes fast wearing and with that follows a highly reduced lifetime.
- Check that the flywheel is placed in the center and with plane rotation.
- Grind the brake belt contact surface, see section "Brake belt contact surface" (once a year).

## Batteries

If the display is battery-operated, the batteries are in a separate package at delivery. If the storing time has been long the battery power can be too low to make the computer act correctly. Batteries must then be changed.

## Flywheel bearing

The flywheel bearing is long-term greased and requires no supplementary lubrication. If a problem arises, please contact your Monark dealer.

## Crank bearing

The crank bearing is greased and normally requires no supplementary lubrication. If a problem arises, please contact your Monark dealer.

## Transportation

During transport the brake cord should be tightened to prevent it from falling off the flywheel.

## Replacement of brake belt

To replace the brake belt remove covers if necessary. Make sure that the belt is loose.

### **Pendulum bike with engine:**

To loosen the brake belt on pendulum bikes with engine, connect power to the unit and raise the pendulum to 4 kp. Hold it there until brake belt is loose. Please note how the belt is assembled. Remove it from the bike. Attach the new brake belt and assemble the bike in reverse order.

### **NOTE!**

When replacing the brake belt it is recommended to clean the brake surface. See "Brake belt contact surface".

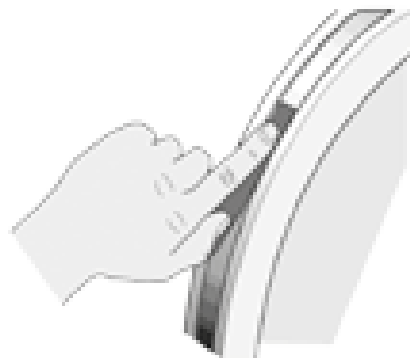
## Brake belt contact surface

Deposits of dirt on the brake belt and on the contact surface may cause the unit to operate unevenly and will also wear down the brake belt. The contact surface of the flywheel should be smoothed with fine sandpaper and any dust removed with a clean dry cloth.

Remove covers, loosen the tension on the brake belt and remove it. Grind with a fine sand paper. Grinding is easier to perform if a second individual cautiously and carefully pedalling the cycle.

Irregularities on the brake belt contact surface are removed by means of a fine sand paper or an abrasive cloth. Otherwise unnecessary wear on the brake belt may occur and the unit can become noisy.

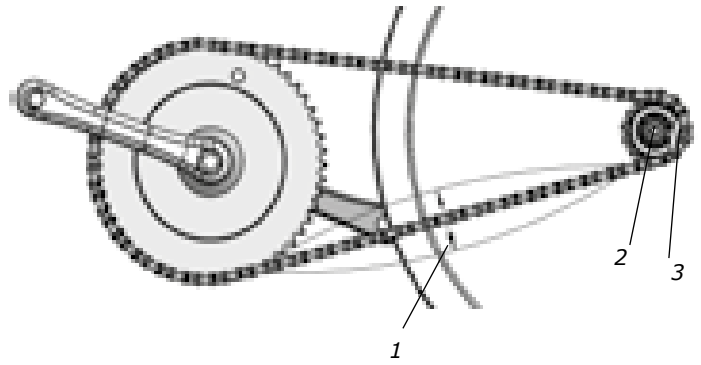
Always keep the brake belt contact surface clean and dry. No lubricant should be used. We recommend replacing the brake belt when cleaning the contact surface. In regard to assembly and adjustment of the brake belt, see "Replacement of brake belt".



*Fig: Brake belt contact surface*

## Chain 1/2" x 1/8"

Check the lubrication and tension of the chain at regular intervals. In the middle of its free length the chain should have a minimum play (3) of 10 mm (1/4 inch). See *Fig: Chain adjustments*. When the play in the chain is about 20 mm (3/4 inch) the chain must be tightened. Otherwise it will cause abnormal wear of the chain and sprockets. Therefore it is always recommended to keep the chain play as small as possible. Loosen the hub nut (2) on both sides and tense the chain with the chain adjuster (1) when needed.



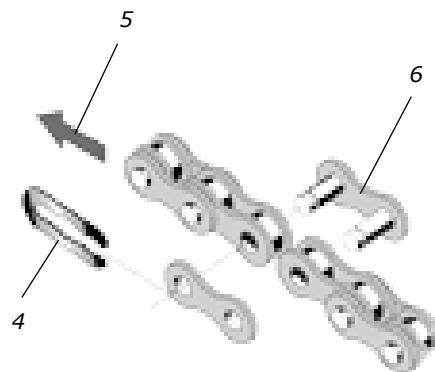
*Fig: Chain adjustments*  
1) Chain adjuster  
2) Axle nut  
3) Chain play

When the chain has become so long that it can no longer be tightened with the chain adjusters it is worn out and should be replaced with a new one.

To adjust or replace the chain, remove covers if required.

To adjust the chain the hub nuts (2) should be loosened. Loosening or tightening the nuts on the chain adjusters (1) will then move the hub and axle forward or backward. Then tighten the nuts on the hub axle again. See *Fig: Chain adjustments*.

To replace the chain, loosen the chain adjusters as much as possible. Dismantle the chain lock (6) and remove the chain. Use pliers to both release the lock washer and mount it again (4). Put on a new chain and assemble the chain lock. The chain lock washer should be assembled with the closed end in the chain's movement direction (5). See *Fig: Chain replacement*.



*Fig: Chain replacement*  
4) Lock spring  
5) Movement direction  
6) Chain lock

### NOTE!

At assembly the flywheel has to be parallel with the centerline of the frame. Otherwise the chain and sprockets make a lot of noise and wear out rapidly.

Then assemble the removed parts as above but in reverse order.

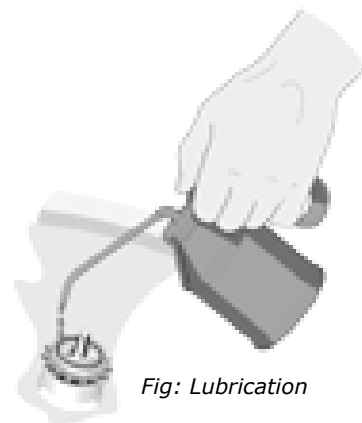


## Freewheel sprocket

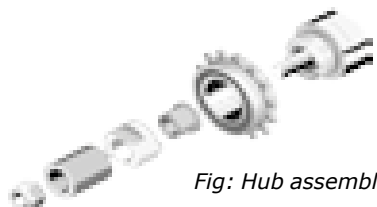
When replacing the freewheel sprocket remove frame covers if necessary. Remove the chain according to section "Chain 1/2" x 1/8".

Loosen the axle nuts and lift off the flywheel. Remove the axle nut, washer, chain adjuster and spacer on the freewheel side. Replace sprocket-adaptor and assemble the new parts in reverse order according to the above.

The sprocket should be lubricated with a few drops of oil once a year. Tilt the cycle to make it easier for the oil to reach the bearing. See *Fig: Lubrication*.

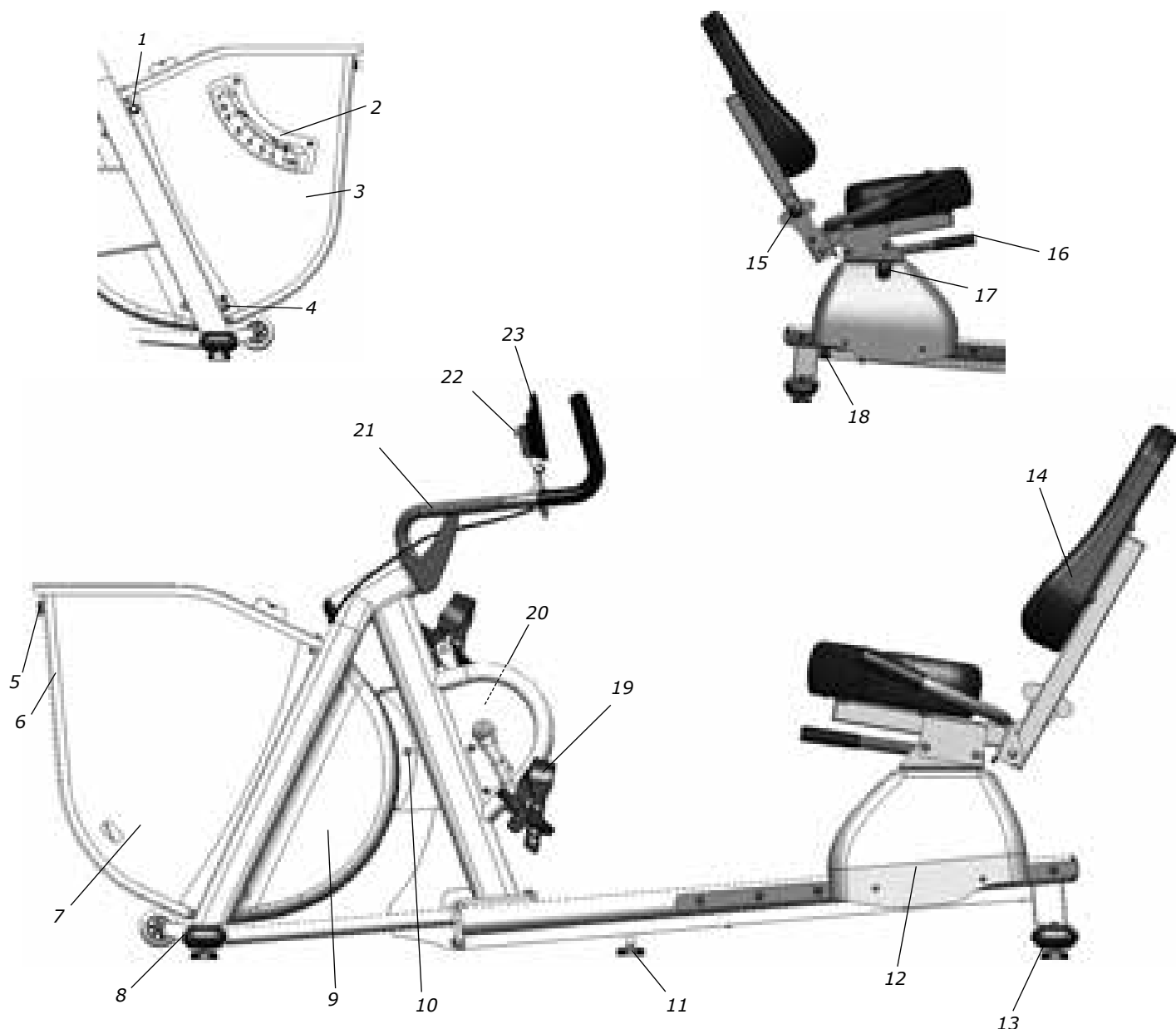


*Fig: Lubrication*

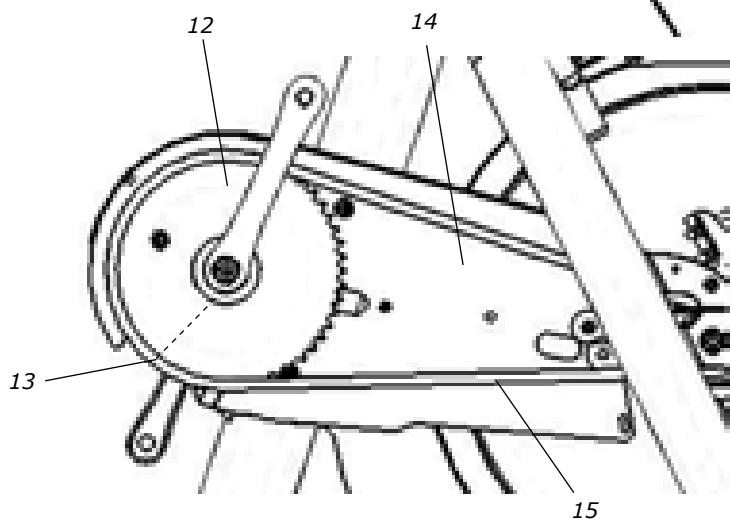
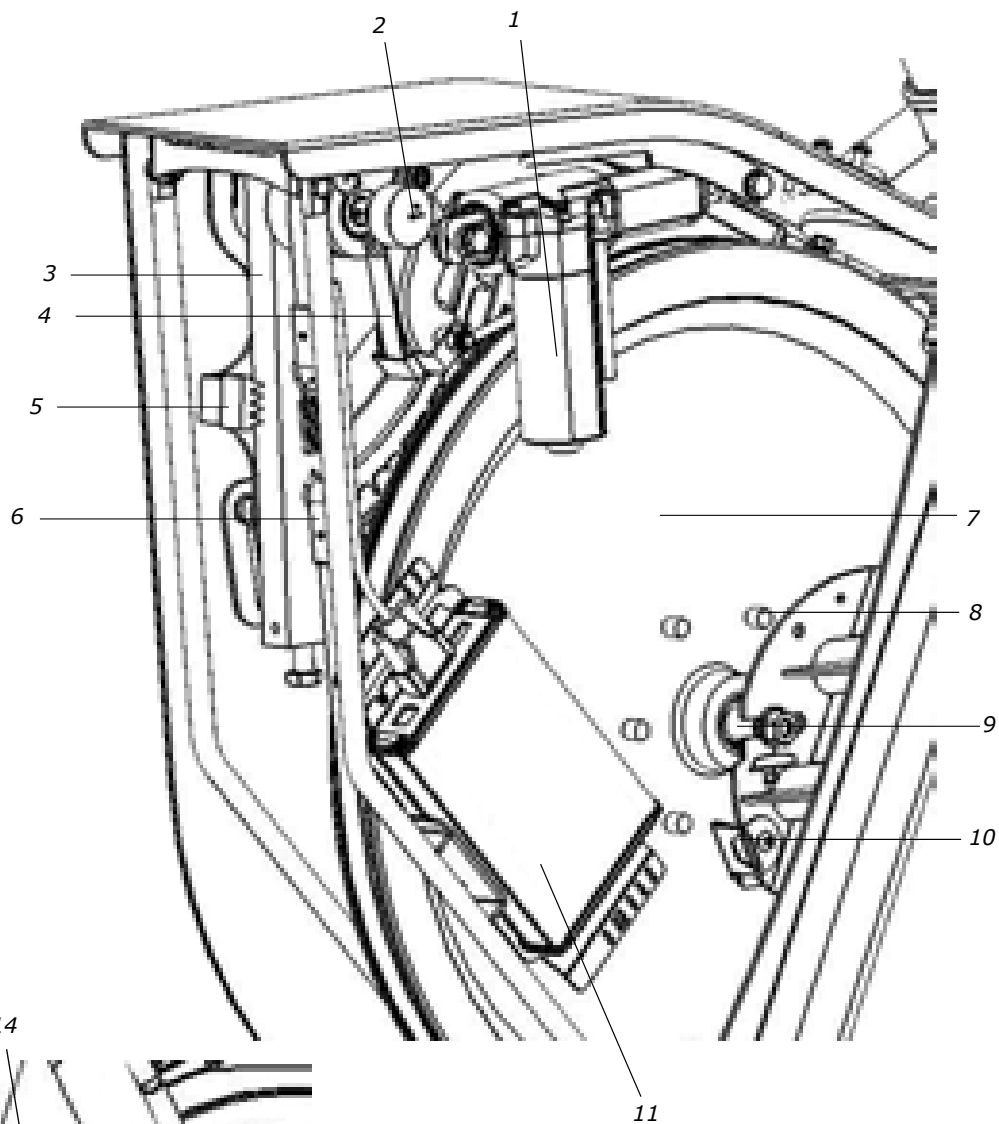


*Fig: Hub assembly*

# Spare parts list



Pos.	Qty.	Art. No.	Description	Pos.	Qty.	Art. No.	Description
1	1	9384-48	Power switch with LED	12	1	9327-84	Cover
2	1	9310-13	Scale 7 kp, complete	13	1	9301-145	Support tube rear, complete
	1	9310-152	-Scale		2	9309-51	-Plastic cap
	1	9000-103	-Pole screw M5x12, white		2	9328-26	-Rubber foot with screw M8
3	1	9310-620	Side cover, right	14	1	9329-3	Seat for recumbent, complete
4	1	8243-7	Holder for cable	15	1	9308-133	-Locking knob
5	1	9310-71	Lock to front cover	16	1	9311-125	Swivel module
6	1	9310-20	Front cover	17	1	9326-97	Lever for length adjustment
7	1	9310-630-1	Side cover, left	18	2	9311-142	Stop
8	1	9301-4	Support tube front, complete	19	1	74435-1	Pedals for recumbent, pair
	2	9328-51	-Plastic cap	20	1	9311-36	Side cover rear, right
	2	9328-26	-Rubber foot with screw M8	21	1	9311-86	Handlebar for recumbent, complete
	2	9000-38	-Transport wheel, complete	22	2	9312-12	Knurled screws
9	1	9310-605	Side cover rear, left	23	1	9311-91	Monark novo display unit
10	1	9000-103	-Pole screw M5x12, white		1	9000-211	Calibration weight 4 kg
11	1	9328-26	Rubber foot with screw M8		1	9312-31	Chest belt Polar H7



Pos.	Qty.	Art. No.	Description	Pos.	Qty.	Art. No.	Description
1	1	9310-56	Motor package, complete	7	1	9300-31	Flywheel, complete with magnets
	1	9310-55	-Motor	8	6	9374-16	-Magnets
2	1	9311-67	Potentiometer with cable	9	1	9300-24	-Flywheel suspension, complete
3	1	9310-45	Pendulum 7 kp, complete	10	1	9311-84	Sensor with bracket, complete
	1	9310-43	-Pointer	11	1	9311-906	Monark novo control unit RC6
	1	9326-88	-Spring	12	1	9300-430	Crank set, steel, 52T, 170 mm
4	1	9100-26	Tension cylinder	13	1	9300-340	Cartridge bottom bracket 68/122 mm
5	2	9300-99	Stop	14	1	9311-6	Chain guard
6	1	9310-94	Brake belt, complete	15	1	9310-118	Chain 9300, 120 L, with chain lock
	1	9311-9312	Power cord for power adaptor, EU		1	9311-9311-1	Power adaptor

**PRODUCTS FOR LIFE AND PERFORMANCE**



CE 0402

Version 1703  
Art. No.: 7950-406